

# Soil-XCell System Operation & Instruction Manual



## ENVIRONMENTAL EXPRESS

800.343.5319 or 843.881.6560 ■ Fax 843.881.3964 ■ [www.environmentalexpress.com](http://www.environmentalexpress.com)

<b>Contents</b>	<b>1</b>
<b>About Your Soil-XCell System</b>	
- Model Information / Specifications	<b>2</b>
<b>Soil-XCell System Part Numbers</b>	<b>3</b>
<b>Adaptation of EPA Method 3546 for Use with Your HotBlock</b>	
- Method Adaptation / Recommended Surrogates and Consumables	<b>4-5</b>
<b>About Your HotBlock</b>	
- Installation Requirements / General Information	<b>6</b>
- Adjusting the Temperature of Your HotBlock	<b>7</b>
<b>HotBlock Safety Information</b>	<b>8</b>
<b>HotBlock Circuitry Diagram</b>	<b>9</b>
<b>HotBlock Troubleshooting Guide</b>	<b>10-12</b>
<b>HotBlock Declaration of Conformity / Record Your Product Information</b>	<b>13</b>
<b>HotBlock Warranty Information</b>	<b>14</b>

## Soil Extraction Cells are designed to work with our 100mL HotBlocks.

Environmental Express, known for its innovative products, has developed the Soil-XCell System for the extraction of semi-volatile organic compounds in soil samples. The Soil-XCell System meets the requirements of the Performance Based Measurement System established by the EPA and replaces microwave technology with a HotBlock and stainless steel Soil Extraction Cells. Analytical results of a CRM (Certified Reference Material) for PAH/BNA and TPH fell within the required acceptance limits and were very reproducible. Real world soil samples were also extracted using this procedure for PAH/BNA and PCB compounds and compared to results achieved using SW846 Method 3545A. Results were comparable for both groups of compounds.

The **K8150 Soil-XCell System** features a 25-well HotBlock and accommodates 25 Soil Extraction Cells while the **K8151** features a 35-well block and holds 35 cells.

Each system comes with the appropriate number of **Soil Extraction Cells**, one **Temperature Reference Cell** and **aluminum racks** for easy handling.

### Soil Extraction Cell Specifications:

- Stainless Steel Body
- Aluminum Threaded Outer Cap
- Stainless Steel Inner Lid with Rupture Seal
- Viton® O-ring

**Soil-XCell System**  
**25-Sample Capacity HotBlock and Racks**  
**Catalog # K8150**

**Soil-XCell System**  
**35-Sample Capacity HotBlock and Racks**  
**Catalog # K8151**

**Individual Soil Extraction Cell Complete, Each**  
**Catalog # K8000**

**Temperature Reference Cell Complete, Each**  
**Catalog # K8000R**

*Replacement parts, see page 3.*



*The Soil Extraction Reference Cell is used to monitor the internal temperature of the solvent during the extraction process. This cell can be used for a sample extraction and should follow the same procedure as the regular K8000 Soil Extraction Cell. One reference cell is provided with each complete system.*

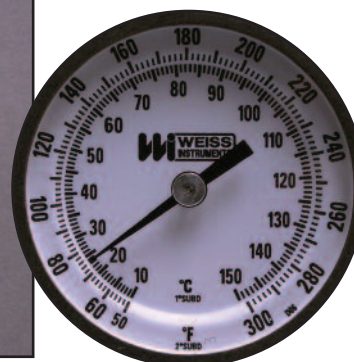

HotBlock Specifications:	K8150	K8151
Footprint:	15" x 15"	15" x 21.5"
Crated Size:	23" x 23" x 17"	26" x 23" x 17"
Weight:	42 lb.	59 lb.
Shipping Weight:	54 lb.	65 lb.
Electrical:	120VAC, 9A	120VAC, 13A
Sample Capacity:	25	35
Temperature Range:	to 150°C	to 150°C
Thermocouple:	Type K	Type K

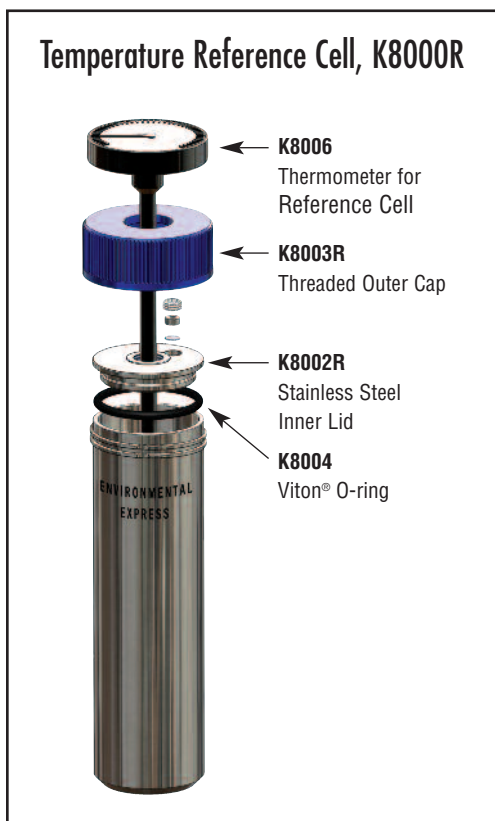

## Soil-XCell Systems

- Catalog # K8150 Soil-XCell System with 25-well HotBlock comes with 24 Soil Extraction Cells, one Reference Cell and one 10-place Aluminum Rack and one 15-place Aluminum Rack.
- Catalog # K8008-25 Rack Set for K8150
- Catalog # K8151 Soil-XCell System with 35-well HotBlock comes with 34 Soil Extraction Cells, one Reference Cell and two 10-place Aluminum Racks and one 15-place Aluminum Rack.
- Catalog # K8008-35 Rack Set for K8151

## Soil Extraction Cell Parts

- Catalog # K8000 Soil Extraction Cell Complete, Each
- Catalog # K8003 Threaded Outer Cap, Each
- Catalog # K8002 Stainless Steel Inner Lid, Each
- Catalog # K8004 Viton® O-ring, 25/pk
- Catalog # K8007 Aluminum Foil Rupture Seal, 100/pk
- Catalog # SC150 25-Well HotBlock
- Catalog # SC151 35-Well HotBlock

## Temperature Reference Cell Parts

- Catalog # K8006 Thermometer for Reference Cell, Each
- Catalog # K8003R Threaded Outer Cap for Reference Cell, Each
- Catalog # K8002R Stainless Steel Inner Lid for Reference Cell, Each
- Catalog # K8004 Viton® O-ring for Reference Cell, 25/pk
- Catalog # K8007 Aluminum Foil Rupture Seal, 100/pk
- Catalog # K8000R Individual Temperature Reference Cell Complete, Each

## Adaptation of EPA SW846 Method 3546 for use with the Environmental Express HotBlock

### Scope and Application:

The following procedures have been written as an aid to EPA SW846 Method 3546 for use with the Environmental Express HotBlock. EPA SW846 Method 3546 is a procedure for extracting water insoluble or slightly water soluble organic compounds from soils, clays, sediments, sludges, and other solid wastes. Prior to using this method, users are advised to consult the determinative method for additional information on quality control procedures, development of QC acceptance criteria, calculations, and general guidance.

### Apparatus and Materials:

1. HotBlock for Sample Extraction – Model Numbers SC150 or SC151
2. Soil Extraction Cell, Complete Unit – Catalog# K8000
3. Soil Extraction Temperature Reference Cell Complete – Catalog# K8000R
4. Drying Agent such as Diatomaceous Earth or Sodium Sulfate
5. Extraction Solvents
6. Buchner Funnel
7. Filter Paper (Glass Fiber)
8. Surrogates
9. Standards
10. Vials

### HotBlock Procedure for Method 3546:

1. When practical, air dry the sample at room temperature for 48 hours in a glass tray or on hexane-rinsed aluminum foil. Alternatively, mix the sample with an equal volume of anhydrous sodium sulfate or diatomaceous earth until a free-flowing powder is obtained. A percent dry weight should be performed on a separate aliquot of sample for the percent dry weight calculation at the end of the analysis.
2. Weigh 10 – 30g of sample into the Soil Extraction Cell. Amount may vary depending on individual laboratory needs.
3. Add approximately 30 mls of solvent. (This method was validated using Methylene Chloride. Other solvents may be used but must be validated by the individual laboratory).
4. Add the surrogates and/or spikes listed in the determinative method to each appropriate sample.
5. Place the stainless steel inner lid with Viton® O-ring in the Soil Extraction Cell.
6. Hand-tighten the threaded outer cap onto the Soil Extraction Cell.
7. Heat the HotBlock to 130° C. This will yield an internal solvent temperature of 100 – 115° C which is recommended by Method 3546.
8. Put the Soil Extraction Cells into the HotBlock and heat for 30 minutes at a block temperature of 130° C. This will give samples 10 – 20 minutes at the appropriate temperature for extraction which is recommended by Method 3546.
9. Remove the cells and allow them to cool to room temperature.

10. Unscrew the threaded outer cap and remove. Take care in doing this step as pressure will develop in the Soil Extraction Cells during the heating process.
11. Take out the stainless steel inner lid and rinse with the appropriate solvent, taking care to collect this rinsate in the cell.
12. Proceed with filtering and rinsing, collecting all filtrates. A Buchner funnel with vacuum is recommended but any appropriate laboratory filtration device may be used.
13. The extract is now ready for concentration, cleanup, and analysis.

All QC samples, limitations, interferences, and reagent specifications are addressed in depth in EPA Method 3546. Safety concerns are also part of the full method. Follow the instructions listed in EPA Method 3546. These steps should only be used as a guide.

### Recommended Surrogates and Other Consumables:

Catalog # M0011	Base-Neutral, 100 ug/mL; Acid, 100 ug/mL, 25mL
Catalog # M0013	Base-Neutral, 100 ug/mL; Acid, 100 ug/mL with CLP, 25mL
Catalog # M0030	Nonatriacontane, 80 ug/mL; O-Terphenyl, 80 ug/mL, 25mL
Catalog # GCS130023-07	Pesticide/PCB Surrogate Solution, 200µg/mL, 1mL
Catalog # GCS011025-01	Herbicide Surrogate Solution, 2000µg/mL, 1mL
Catalog # K6180-4	Pelletized 60 Mesh Diatomaceous Earth, 4kg
Catalog # LC248801	Sodium Sulfate, Anhydrous, 500g

## Environmental Express HotBlock™

Environmental Express HotBlocks provide an efficient method of extracting water insoluble or slightly water soluble organic compounds from soils, clays, sediments, sludge, and other solid wastes. In addition, samples are handled in a small area with minimal radiant heat loss. Users should be aware of potential dangers from heating certain types of compounds. Such hazards may include explosion or the release of toxic or flammable gases.

## Unpacking Your HotBlock

Remove the HotBlock from the shipping container. Always lift the HotBlock from the bottom of the unit. Never use the lid for lifting. Your HotBlock is shipped with metal screws securing the bottom panel. The metal screws must be removed before operating your HotBlock. Remove the metal screws and replace them with the PVC screws and rubber feet included with your shipment. The corrosion-resistant PVC screws and rubber feet are designed to secure the bottom plate.

**IMPORTANT: DO NOT OVER TIGHTEN THE PVC SCREWS!**

## Definitions/Markings

Each HotBlock displays certain markings and symbols. All personnel working with the HotBlocks should have an understanding of the following symbols and definitions:

### Definitions and Symbols:

- V = voltage
- ~ = alternating current
- Hz = frequency
- A = amperes



This symbol means “**Caution Hot Surface**”. The surface of the HotBlock may be too hot to safely touch with bare hands.



This symbol means “**Read and become familiar with instructions before operation of instrument**”.

## Installation Requirements

Locate the HotBlock under a fume hood with a minimum face velocity of 100fpm, and allow a minimum of 2" of space on all sides. The following environmental conditions should be observed:

- Ambient temperature range: 5-30°C
- Ambient relative humidity: 0-90%RH
- Altitude: sea level to 2500 meters

HotBlocks are rated as **Pollution Degree 2** and **Installation Category 2**.

## Electrical Requirements

- Required Voltage: 120 volts, ~60Hz, 15A  
(all HotBlocks are also available in 240V with CE mark)

Power should not vary more than  $\pm 10\%$ . Use the supplied heat-resistant power cord or equivalent to connect to the power supply.

For safety reasons, a separate power receptacle should be provided for each unit in the system. Do not use extension cords or outlet adaptors. Make certain that power outlets are earth-grounded at the grounding pin.

See individual specifications for each HotBlock model.

## HotBlock Temperature Settings:

The pre-set factory “set point” temperature of your HotBlock is 106°C. Factory tests have shown that this temperature is “sea level safe.” Please note that the set point of the block is not the same as the internal temperature of the Soil Extraction Cell. The block temperature should be optimized for the desired temperature. The temperature of the Soil Extraction Cell will vary according to:

- The material being extracted
- The number of samples being extracted
- The air movement of the digestion area

**Note:** *Remember that the temperature display (current block temperature) is not the temperature of the sample. Sample temperature will usually be 15-20° less than the display temperature.*

## Adjusting the Temperature of Your HotBlock:

- Plug the HotBlock into an approved receptacle. Turn the HotBlock on by pressing the button on the back of the unit. Wait until the display shows the current block temperature (in Red) and the set point temperature (in Green).
- Press and hold or tap the ▽ or △ key. The display will show the set point temperature on the right in Green. The adjustment is from ambient to 150°C in increments of 0.1°C. There is no need to press the Green (advance) or ∞ button.

## Safe-Sample™ Temperature Protection:

Your HotBlock is protected from runaway temperatures by a fail-safe alarm system. In the unlikely event that the heating system fails to respond to the controller, the Safe-Sample™ system will automatically shut the system off and sound an audible alarm. This alarm sequence occurs if the actual temperature of the block reaches a temperature that is fifteen degrees higher than the set point temperature. If this should occur, the HotBlock will stop heating, preventing the loss of samples. The HotBlock must be turned off, then turned back on to reset the alarm. If the alarm sounds, see the trouble shooting section of this manual.

## Potential Hazards:

***The HotBlock should only be operated by properly trained personnel using standard laboratory safety practices.***

Use extreme caution when operating the HotBlock. Plastic and graphite surfaces of the HotBlock may be too hot to safely touch with bare hands.

The HotBlock contains electrical circuits and devices and compounds operating at dangerous voltages. Contact with these circuits, devices and components can cause serious injury or painful electric shock.

Proper grounding is essential to avoid a potentially serious electric shock hazard. Ensure that there is an internal ground connection between the metal base of the system and the 3-pin, earth-grounded receptacle.

For safety reasons a separate power outlet receptacle should be provided for each unit in the system. Do not use extension cords or outlet adaptors. Make certain each power outlet is earth-grounded at the grounding pin.

See individual block specifications for power requirements.

Application of the wrong supply voltage can create a fire hazard and a potentially serious shock hazard, and could seriously damage the HotBlock system. See specifications for individual HotBlocks.

Users should be aware of potential dangers from heating certain types of compounds. Such dangers may include explosion or the release of toxic or flammable gases.

Always lift the HotBlock from the bottom of the unit.

## Maintenance:

Any service inquiries should be directed to Environmental Express Technical Service Department. After each use, clean exterior surfaces with a damp sponge to remove residue. Before using any cleaning or decontamination methods except those recommended, check with Environmental Express to confirm the proposed method will not damage your HotBlock.

***Avoid excessive spills, as liquid allowed to overflow into the HotBlock casing can severely damage electronic components.***

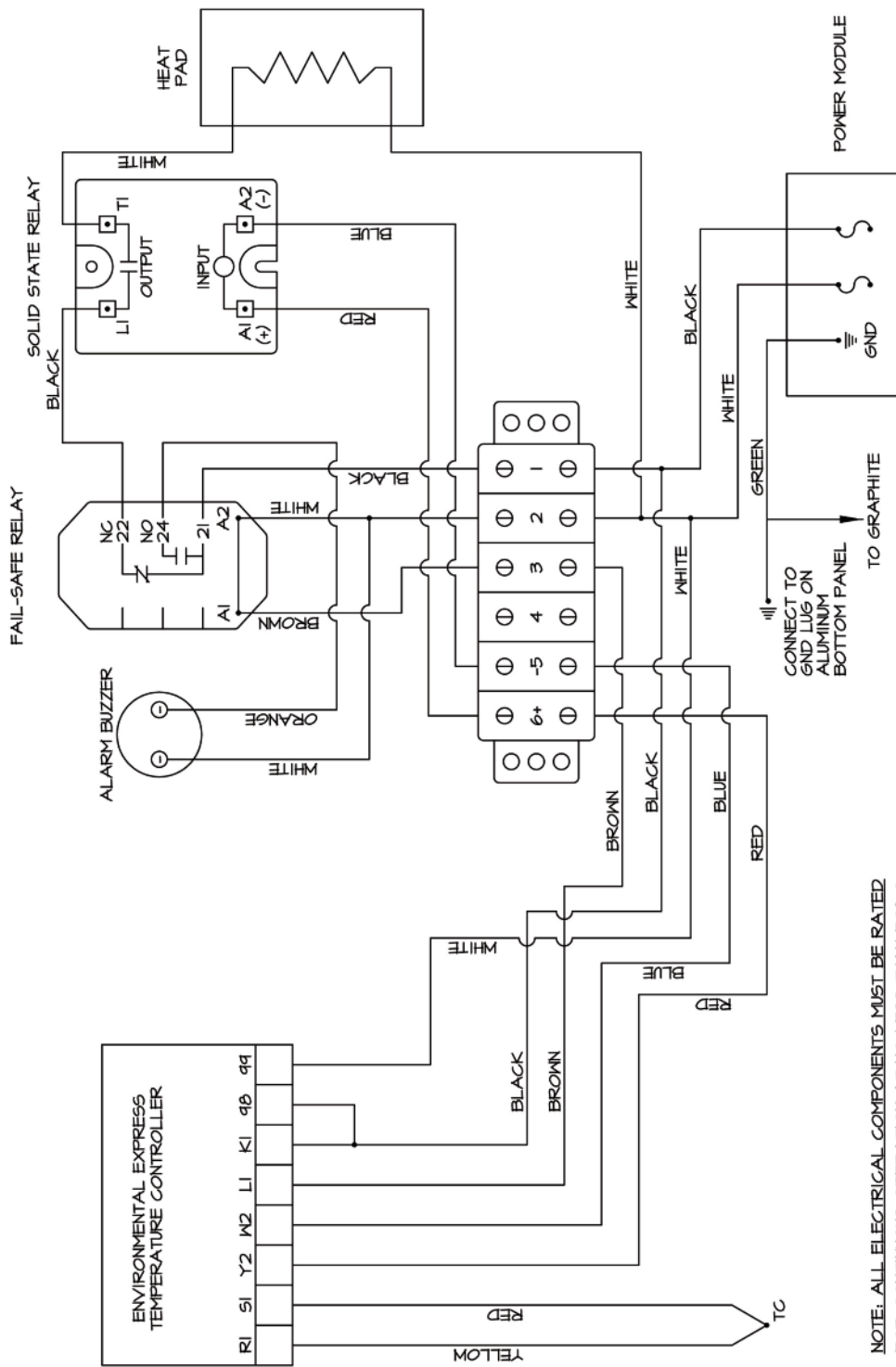

BLOCK DIAGRAM FOR HOT BLOCK  
ELECTRICAL CONTROLS

ENVIRONMENTAL EXPRESS  
REVISED 2-10-10  
D043480IR1

Please consult the following troubleshooting guide if you experience problems with your HotBlock. See wiring schematic for component identification. If you are unable to resolve the problem or if replacement components are necessary, please contact technical service at 1-800-745-8218. Component replacement varies in degrees of difficulty. We recommend that only qualified personnel attempt troubleshooting electrical components.

When the HotBlock is initially powered on, the controller will cycle through a self-test sequence. It will then display the current temperature and begin heating until it reaches your set point temperature, where it will hold until the unit is powered off. The set point may be changed at any time. A change in the controller's factory default settings or a failed component may cause the HotBlock to perform unsatisfactorily or render it inoperable.

## The controller digital display will not illuminate.

***There are two possible reasons that your controller will not illuminate.***

- ***The controller is not getting voltage or;***
- ***The controller itself has failed internally.***

***The problem can be effectively diagnosed by determining if the controller is or is not getting voltage using the following steps:***

1. Confirm that the power cord is plugged securely into the HotBlock receptacle and a working outlet.
2. Confirm that the switch is in the "on" position. Press button on the back of HotBlock.
3. Check the fuse located in the power module:
  - a) Locate the fuse drawing indented into the power module next to the socket.
  - b) Using a small screwdriver, pry open the fuse compartment cover.
  - c) Examine the exposed fuse for a break in the filament and if necessary, check for continuity using a volt-meter.
  - d) If the fuse is determined to be blown, replace it with the spare fuse located in the slide-out compartment beneath the operating fuse.



***Caution: This procedure is a potential electrical hazard and should only be performed by qualified personnel.***

4. Inside the HotBlock, check voltage leading from the power module to the controller:
  - a) Remove the bottom panel of the HotBlock by unscrewing the rubber feet.
  - b) On the back of the controller, locate the black wire at terminal 98 and white wire at terminal 99.
  - c) Set your volt-meter on AC voltage.
  - d) Touch your red lead to the exposed white wire and black lead to the exposed black wire.
  - e) If your volt-meter reads 110-122V, the controller is receiving power but has failed internally. It must be replaced.
  - f) If your volt-meter registers less than 110-122V, using step **d** above check the black and white wires at the terminal board and then at the power module to determine if there is a faulty connection.

## The audible alarm sounded *immediately* after powering on and the HotBlock will not heat.

***There are two possible causes for your HotBlock to sound the alarm immediately after the controller cycles through the self test.***

- ***Your set point has been set to a value ( $\geq$ ) 15° less than ambient or current set point temperature. Turn the set point to within 15° of the actual temperature (blue numbers).***
- ***The controller is faulty. Call Environmental Express at 1-800-343-5319 for more information.***

The temperature overshoot the set point and the audible alarm sounded.

*The function of the fail-safe system is to cease heating of the HotBlock in the event of a set point overshoot of 15°C and to alert the technician of the incident. The HotBlock can be “fooled” into fail-safe mode if the set point is manually changed to a value  $\geq 15^\circ$  below your current temperature. However, the primary cause for the runaway temperature is a faulty relay that has exceeded its useful life. You may troubleshoot the relay by following these steps:*



**Caution:** *This procedure is a potential electrical hazard and should only be performed by qualified personnel.*

1. Power off your HotBlock.
2. Remove the bottom panel of the HotBlock by unscrewing the rubber feet.
3. Power the HotBlock on and allow it to overshoot your set point temperature.
4. Locate the solid state relay mounted to the bottom panel.
5. Set your volt-meter to measure AC voltage.
6. Touch your red lead to terminal T1 (white wire) of the solid state relay and touch your black lead to a ground source (e.g., the green/yellow wire from the power module or an empty terminal on the terminal board).
7. If your volt-meter reads 110V-122V, then the relay is stuck in the “closed” position and it must be replaced.

**The HotBlock will not heat beyond ambient temperature.**

***A HotBlock that will not heat beyond ambient temperature typically has a failed relay, heater mat or controller.***

- **Relay**—*To test the relay, the output voltage must be determined with a volt-meter.*



**Caution:** *This procedure is a potential electrical hazard and should only be performed by qualified personnel.*

***To measure the relay voltage, follow these steps:***

1. Remove the bottom panel of your HotBlock by unscrewing the rubber feet.
2. Locate the solid state relay mounted to the bottom panel.
3. Set your volt-meter to measure AC voltage.
4. Touch your red lead to terminal T1 (white wire) of the solid state relay and touch your black lead to a ground source (i.e., the green/yellow wire from the power module or an empty terminal on the terminal board).
5. If your volt-meter does not read 110V-122V, then the relay has stuck in the “open” position and it must be replaced.

- **Heater Mat**—*To test the heater mat, the resistance (ohms) must be determined with a volt-meter. It is recommended that your heater mat be replaced if it measures 25 ohms ( $\Omega$ ) or greater. It is also recommended that the thermocouple and insulation be replaced as well, both are inexpensive parts that are not easily accessible otherwise.*

***To measure your heater mat resistance, follow these steps:***

1. Power off your HotBlock and remove the bottom panel of your HotBlock by unscrewing the rubber feet.
2. Locate and disconnect the white wire connected to terminal T1 of the relay and an identical wire on terminal #2 of the terminal board (note: terminal #2 of the terminal board contains 3 white wires. To ensure you have the correct wire, trace it back and ensure it originates from the graphite portion of your HotBlock).
3. Set your volt-meter to measure ohms  $\Omega$ .

4. Touch the red lead to one of these wires and touch the black lead to the remaining wire.
  5. If your reading is "OL" (over limit) or a value greater than 25 ohms, then the heater mat has failed and it must be replaced.
- **Controller**—*To test the controller, the output voltage must be determined with a volt-meter. To measure voltage from the controller, follow these steps:*



**Caution:** *This procedure is a potential electrical hazard and should only be performed by qualified personnel.*

1. Remove the bottom panel of your HotBlock by unscrewing the rubber feet.
2. Locate the solid state relay mounted to the bottom panel.
3. Set your volt-meter to measure DC voltage.
4. Touch the red lead to terminal A1 (RED) and the black lead to terminal A2 (BLUE) of the solid state relay.
5. Your volt-meter should read 3V-16V.
6. If your volt-meter does not read 3V-16V, perform steps 3 and 4 on the red and blue (5 and 6) wires at the terminal board and controller to determine if there is a faulty or loose connection.
7. If you do not get a reading of 3V-16V at terminals Y2 (red) and W2 (blue) of the controller then the controller has failed internally and it must be replaced.

**The temperature controller is performing erratically or displays an error message.**

**The temperature controller is flashing Er.L Attn- Thermocouple Fault**

***First reset default settings***

1. Hold the up and down arrow buttons for six seconds until **Ai Set** appears
2. Hold the down arrow until **gbl set** is in the window
3. Press the green **advance** key to enter
4. Continue pressing the green advance key until **none user** appears.
5. Press the down arrow key until **Set1 user** appears.
6. Pressing the advance key will restore default settings.

***To troubleshoot the thermocouple, follow these steps:***

1. Power off your HotBlock.
2. Remove the bottom panel of your HotBlock by unscrewing the rubber feet.
3. Locate the thermocouple wires at terminals R1 (yellow) and S1 (red) of the controller and remove using a small screwdriver.
4. Cut the exposed ends of the two wires.
5. Strip 1/4" of insulation from each wire and reconnect them to the appropriate controller terminal and tighten.
6. Power on your HotBlock.
7. If your display continues to flash Er.1 Attn- the thermocouple is faulty and must be replaced (see parts list, page 10).

**The manufacturer,**

Environmental Express  
490 Wando Park Blvd., Mt. Pleasant, SC 29464

**declares that the following products:**

HotBlock Catalog Numbers- SC196, SC154, SC150, SC151, SC100, and C6002  
K8150, K8151



4000040

**Standard for Safety Electrical Equipment for Measurement, Control, and Laboratory Use; Part 1 General Requirements, UL 61010-1, CAN/CSA-C22.2 No. 61010-1, 2nd Edition, Issued 12 July, 2004 with revisions through and including 28 October, 2008; Equipment for Measurement, Control, and Laboratory Use Part 2-010: Particular Requirements for Laboratory Equipment for the Heating of Materials, IEC 61010-2-010, 2nd Edition, Issued 1 June, 2003, Safety Requirements for Electrical Equipment for Measurement, Control, and Laboratory Use - Part 2-010: Particular Requirements for Laboratory Equipment for the Heating of Materials, CSA C22.2.61010.2.01**

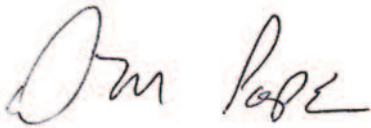
Signed: 

Dennis Pope, Chief Executive Officer

<b>PRODUCT INFORMATION:</b>	
Catalog # _____	Date of Purchase _____
HotBlock Serial # _____	
(Please record the serial # of your HotBlock here for easy reference. Your serial # is located on the back of your block.)	

# HotBlock™ Limited Warranty

**T**he Environmental Express HotBlock is warranted against defects in materials and workmanship when used in accordance with applicable instructions, for a period of one year from the date of shipment. This warranty extends to parts, labor, and any approved transportation charges. This warranty applies only to damage or failure caused by normal laboratory use. The warranty is limited to product repair. If Environmental Express is unable to repair the HotBlock, the customer may, at his or her option, receive a replacement unit or a full refund. ***Operating the HotBlock at temperatures higher than 150°C will void the warranty.***

***Environmental Express makes no other warranty, expressed or implied for this product with respect to merchantability, fitness for a particular use or any other matter. Environmental Express is not liable for any consequential or compensatory damages arising from use of, or in conjunction with this product. The maximum liability shall be the invoice price of this product.***

## **REPAIR POLICY — Under Warranty Repair:**

If the HotBlock should fail to operate within the warranty period (one year from date of shipment) Environmental Express will repair it and ship it back to the customer at our expense. The remainder of the warranty period will be honored from the original ship date. Environmental Express will bear the cost of ground transportation both to and from the customer's location, and bear the cost of any parts, labor and cleanup required. However, if it is determined that the damage to the HotBlock was caused by negligence or improper use, this warranty will not apply. The warranty is also void if the system is used beyond its intended purpose or in the event of any unauthorized repair. In such cases, reasonable and customary repair charges will apply. Repair charges will be quoted prior to work being done.

## **REPAIR POLICY — Out of Warranty Repair:**

**If the HotBlock fails after the warranty period has lapsed, the repair procedure is as follows:**

First, notify an Environmental Express Technical Service Representative of product's failure and place an order for repair. Whenever possible, our customer service technician will walk you through possible troubleshooting scenarios which may enable you to repair your block on site. (See the troubleshooting section of this manual).

If on site repair is not possible, the customer may return the non-working unit to Environmental Express using appropriate shipping containers and insurance. Repair charges will be assessed and estimated prior to work being done. Repair charges will include all freight costs as well as reasonable and customary charges for parts and labor.

*Loaner HotBlocks MAY be available during the repair period. There are only a limited number of these units. A reasonable charge for "cleanup" will be charged if a loaner is issued. The customer will be responsible for all shipping charges associated with a loaner unit.*

# **E N V I R O N M E N T A L   E X P R E S S**

2345A Charleston Regional Parkway, Charleston, SC 29492

800.343.5319 or 843.881.6560 ■ [www.environmentalexpress.com](http://www.environmentalexpress.com)